

A vertical bar on the left side of the page, transitioning from red at the top to blue at the bottom.

vollrath

A blurred, light blue brushstroke background behind the product list text.

Dispersers
Bead-Mills
Mixers
Stirrers

Dispersers

Applications

VOLLRATH-Dispersers are mainly used to disperse pigment, fillers and other powders into liquids or pastes. The large agglomerates being broken down and the solid particles wetted out.



Principle

The principle of the VOLLRATH High Speed Dispenser is to use a specially shaped toothed disc at a very high peripheral tip speed. This ensures that large stress forces break down the agglomerates

into the liquid or paste suspension.

High performance and efficiency

The high power density, the large speed range and the constant power of the variable speed frequency inverter drive gives the VOLLRATH-Dispenser excellent efficiency and maximum flexibility, along with the built-in overload control, which ensures safe and easy processing of all products.

Optimisation

To create maximum shear rate at the premix stage the product is normally worked into a high viscosity liquid or paste, before adding the rest of the liquid, which had been held back.

The following options can be supplied by VOLLRATH to optimise the processing:

- Higher viscosity products are best processed with the Dispenser-Suction-Disc to move the whole batch efficiently.
- Other types and sizes of disc can also be used to suit the particular product to be processed.
- Wall and bottom scraping systems can be added – when the Dispersers are used with a wall and bottom scraper, highly viscous products can be easily processed.
- Vessels can be fitted with heating or cooling jackets.
- Dispersers with conical vessels are normally supplied when a large variation in batch sizes or the whole process has to take place in one vessel.
- VOLLRATH can also supply Dispenser of special execution that can be developed with the customer.
- Universal - Mixing - Dispersers with up to three mixing systems, like the Type VDMP, can be supplied for a wide range of products.



Dispenser-Suction-Disc



Axial-Suction-Disc



Wall and Bottom-Scraper

Laboratory and Trials

The VOLLRATH-Laboratory and demonstration room is available for trials to ensure correct selection of equipment to suit customer's particular requirements.

An adaptation of formulation can be necessary to reach optimal results.

Explosion-proof protection (ATEX)

Dispersers can be supplied according to EC Directive 94/9/EG (ATEX) for use in all zones including zone O. Notified body (PTB) certificates are available where required.



Vacuum-Dispersers

The option "vacuum" is available for the most VOLLRATH-Dispersers.

Construction and Service

All VOLLRATH-Dispersers are solidly built and designed to give a trouble free long service life.



Dispersers
Bead-Mills
Mixers
Stirrers

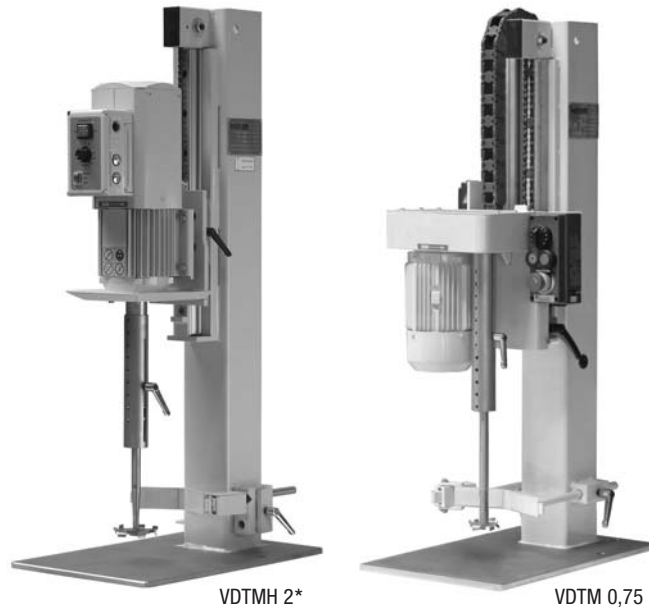

VDTMH 2*

VDTM 0,75

Laboratory-Dispersers

Type	Disc Ø mm	Power kW	Speed min ⁻¹	Lift mm	Container Ø mm	Volume l
VDTM 0,75	50/65	0,55	500-10000	300	100-180	1- 5
VDTMH 2*	50/65/90	1,1	0-12000	300	100-250	1-10

* Explosion proof is not possible.



Laboratory- and Pilot-Plant-Dispersers

Type	Disc Ø mm	Power kW	Speed min ⁻¹	Lift mm	Container Ø mm	Volume l
VDT 2	100	1,1	290-4600	400	150-250	5-15
VDT 3	125	2,2	290-3700	400	175-350	10-20

Dispersers
Bead-Mills
Mixers
Stirrers



To comply with local environmental and safety regulations our wall and stand mounted dispersers are often supplied with lids.

The lid is fixed to the machine head on slides. This allows up and down movement of the disperser disc over its working area, to obtain the optimal mixing effect (Vortex), whilst the lid remaining in contact with the vessel/drum. Lids are fitted with large charging chutes allowing ingredients to be added (with the mixer operating) straight into the vortex. Fast incorporation of the ingredients is therefore ensured.

Sample:

**Disperser Type VDWG 15
with EC-Type Examination Certificate for "Zone 0".**

Disperser fitted with the electro-mechanical lifting option can easily be raised and lowered for vessel/drum removal, along with fine adjustment of the working height to suit mixing requirements.

These mixers offer excellent price/performance ratios.

Explosion Protection

Explosion proof Dispersers with lid or fixed, enclosed systems are normally "Zone 0" (Category 1) rated inside the vessel.

Marking of machines for "Zone 0" / Zone 1

Category 1 / Category 2

vollrath		D 50354 Hürth Max-Planck-Str. 13	
Typ:	VDWG 15		
Baujahr	2008	Masch. Nr.:	25.374
CE 0102	Ex II 1/2 G c IIB T3		
Richtlinie 94/9/EG	03ATEX5007X 08ATEX D011		
nk= 569-715 l/min	P=11 kW, Scheibe max. d=250		



Serial production according to Directive 94/9/EG (ATEX)
for Zone 0, 1, 2, 20, 21, 22

Vollrath has two certified designs for "Zone 0":

- for vessels working with atmospheric pressure.
- for vessels working under vacuum.

All Production-Dispersers have "Zone 0" explosion proof option available!



Wall- or Stand-Dispersers*

Type	Disc Ø mm	Power kW	Speed min ⁻¹	Lift mm	Container Ø mm	Volume l
VDWGM 3	100	2,2	290-4600	500	150-280	5-15
VDWGM 4	125	3	290-3700	500	175-350	10-20
VDWGM 5	150	4	290-3100	500	200-400	15-50



Wall- or Stand-Dispersers*

Type	Disc Ø mm	Power kW	Speed min ⁻¹	Lift mm	Container Ø mm	Volume l
VDWG 5	150	4	290-3100	600	200-400	15- 50
VDWG 7	175	5,5	145-2650	600	350-500	50-100
VDWG 10	200	7,5	145-2300	600	450-600	100-150
VDWG 15	250	11	145-1850	600	550-700	150-250
VDWG 20	275	15	145-1700	600	600-750	200-300
VDWG 25	300	18,5	145-1600	600	700-800	250-400
VDWG 30	350	22	145-1450	600	800-900	400-550

* The stand version has a solid foot made of steel to screw the disperser on floor of hall. Larger speed range on request.



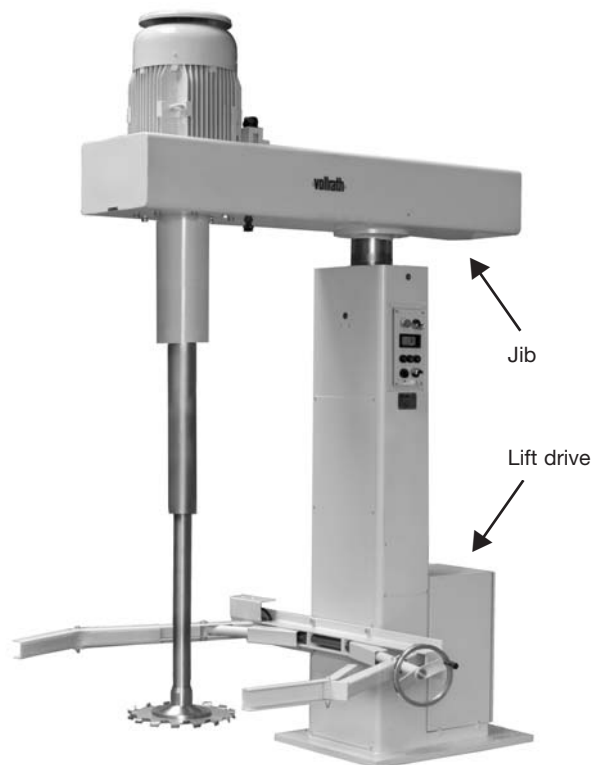

Wall- or Stand-Dispersers

Type	Disc Ø mm	Power kW	Speed min ⁻¹	Lift mm	Container Ø mm	Volume l
VDSW 25	300	18,5	145-1600	1200	800	400
VDSW 30	350	22	145-1550	1200	900	550
VDSW 40	375	30	96-1500	1200	1000	750
VDSW 50	400	37	96-1450	1200	1150	1000
VDSW 60	400	45	96-1450	1200	1200	1300

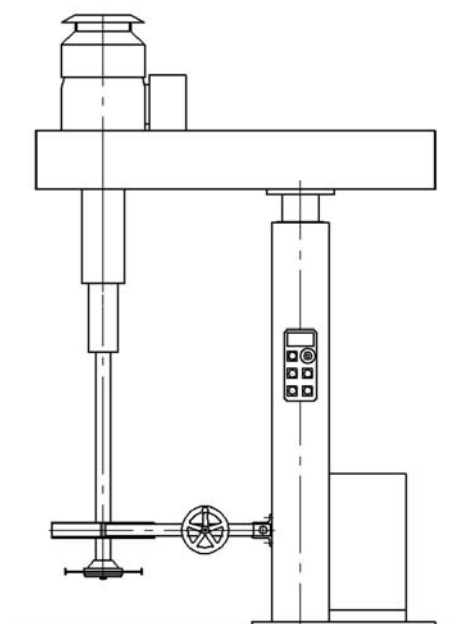

Stand-Dispenser

The Stand-Dispenser is to fasten on floor by screws.

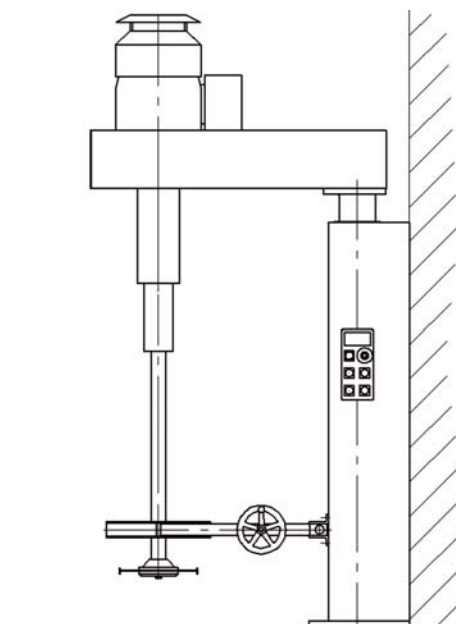

Wall-Dispenser

The jib of Wall-Dispenser is shortened at the back and the lift drive is turned to left side. The machine frame is to fix at wall or column by it's mounting brackets.



Stand-Dispersers*

Type	Disc Ø mm	Power kW	Speed min ⁻¹	Lift mm	Container Ø mm	Volume l
VDS 30	350	22	110-1350	1200	900	550
VDS 40	400	30	100-1150	1200	1000	750
VDS 50	450	37	90-1050	1200	1150	1000
VDS 60	500	45	80- 950	1350	1250	1500
VDS 80	550	55	70- 850	1350	1400	2000
VDS 100	600	75	65- 800	1500	1500	2500
VDS 120	650	90	60- 750	1500	1700	3000
VDS 150	700	110	60- 700	1800	1800	4000
VDS 180	800	132	55- 600	1800	1900	5000

Larger speed range on request.

* Also available as **Pivotal-Dispenser** (turnable head with shaft).

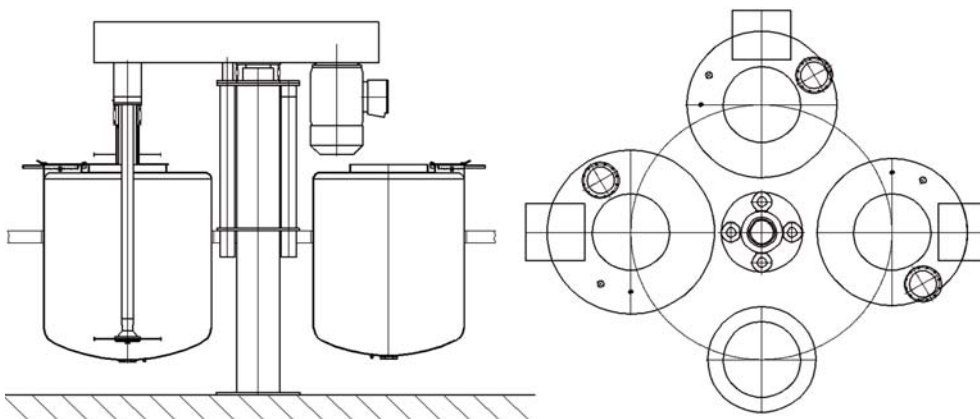

The construction of "Pivotal Dispersers" should be adapted to application and building.

Dispersers
Bead-Mills
Mixers
Stirrers



Stand-Vacuum-Dispersers

Type	Disc Ø mm	Power kW	Speed min ⁻¹	Lift mm	Container Ø mm	Volume l
VDS-VA 40	350	30	110-1350	1200	900	550
VDS-VA 50	400	37	100-1150	1200	1000	750
VDS-VA 60	450	45	90-1050	1350	1150	1000
VDS-VA 80	500	55	80- 950	1350	1250	1500
VDS-VA 100	550	75	70- 850	1350	1400	2000
VDS-VA 120	600	90	65- 800	1500	1500	2500
VDS-VA 150	650	110	60- 750	1500	1700	3000
VDS-VA 180	700	132	60- 700	1800	1800	4000

Special Features

- Vacuum lid is mounted elastic to Dispersers head.
- There is a linear vacuum seal between Dispersers head and vacuum lid. This allows up and down movement of the disperser disc over its working area, to obtain the optimal mixing effect (Vortex), while the lid is closed and Vacuum is given.
- Big rectangular filling mouth with bag support and cover.
- EC-Type Examination Certificate for "Zone 0" available.



Tank-Mounted-Dispersers*

Type	Disperser Disc Ø mm	Power kW	Speed min ⁻¹	Lift mm	Scraper Power kW	Speed min ⁻¹	Volume l
VDUHVV 50	450	37	90-1050	400	1,9	10	800
VDUHVV 60	500	45	80- 950	500	1,9	10	1100
VDUHVV 80	550	55	70- 850	500	2,6	10	1500
VDUHVV 100	600	75	65- 800	700	3,5	10	2000
VDUHVV 120	650	90	60- 750	700	4,8	10	3000
VDUHVV 120	700	90	60- 700	700	6,6	10	4000
VDUHVV 150	800	110	55- 600	800	6,6	10	5000
VDUHVV 180	850	132	50- 550	800	9,7	10	6000
VDUHVV 220	900	160	50- 510	800	13,2	10	8000
VDUHVV 270	1000	200	50- 460	1000	16,5	10	10000
VDUHVV 330	1100	240	40- 420	1000	16,5	10	12000
VDUHVV 400	1200	315	40- 390	1000	18,5	10	15000

* Also available as **Vacuum-Disperser**: Type VDUHVV-VA



Tank-Mounted-Disperser

The "VOLLRATH-Tank-Mounted-Disperser" is a very robust Dissolver, which can be used to process a wide variety of products. The speed of the main shaft is adjustable over its full working range by the frequency inverter, which along with the hydraulic height adjustment allow optimal processing. The optional Anchor, with by-directional, spring loaded side wall and bottom scrapers allow even more processing options. Being top mounted and of a very robust design removes the need for bottom bearings or sealing arrangements within the vessel.

Other options include: Vacuum execution; Conical vessel bottom, which allows the possibility to start processing with a very low quantity of liquid; Heating/cooling using either a double jacket or welded half pipes; Clean In Place high or low pressure system can be mounted on the cover on request.

Special feet plates or sidewall brackets can also be supplied for load cells applications.



Top-Mounted-Dispersers

Type	Disc Ø mm	Power kW	Speed min ⁻¹	Container Ø ¹ mm	Volume l
VD 10 FU	200	7,5	145-2300	550	150
VD 15 FU	250	11	145-1850	650	250
VD 20 FU	275	15	145-1700	750	300
VD 25 FU	300	18,5	145-1600	800	400
VD 30 FU	350	22	96-1300	900	550
VD 40 FU	400	30	96-1200	1000	700

Larger speed range on request.



Top-Mounted-Dispersers

Type	Disc Ø mm	Power kW	Speed min ⁻¹	Container Ø ¹ mm	Volume l
VDU 30 FU	350	22	110-1350	900	550
VDU 40 FU	400	30	100-1150	1000	700
VDU 50 FU	450	37	90-1050	1100	800
VDU 60 FU	500	45	80- 950	1200	1100
VDU 80 FU	550	55	70- 850	1350	1500
VDU 100 FU	600	75	65- 800	1500	2000
VDU 120 FU	650	90	60- 750	1700	3000
VDU 150 FU	800	110	55- 600	2000	5000
VDU 180 FU	850	132	50- 550	2100	6000
VDU 220 FU	900	160	50- 510	2300	8000
VDU 270 FU	1000	200	50- 460	2500	10000
VDU 330 FU	1100	240	40- 420	2600	12000
VDU 400 FU	1200	315	40- 390	2800	15000

Larger speed range on request.

Dispersers
Bead-Mills
Mixers
Stirrers



Universal-Mixing-Dispersers*

Type	Disperser Disc Ø mm	Power kW	Speed min ⁻¹	Mixer Disc Ø mm	Power kW	Speed min ⁻¹	Scraper Power kW	Speed min ⁻¹	Volume l
VDMP 100	2 x 125	5,5	350-3700	3 x 125	2,2	670	1,4	21	100
VDMP 200	2 x 150	7,5	300-3100	3 x 150	4	560	2,5	21	200
VDMP 500	2 x 200	15	250-2300	3 x 200	5,5	420	3,6	21	500
VDMP 1000	2 x 250	22	140-2000	3 x 250	7,5	340	5,5	21	1000
VDMP 2000	2 x 300	30	140-1600	3 x 300	17,5	280	10	21	2000
VDMP 3000	2 x 350	45	110-1350	3 x 350	24	230	15	21	3000
VDMP 4000	2 x 350	55	120-1400	3 x 400	30	200	17,5	16	4000
VDMP 5000	2 x 400	75	100-1200	3 x 400	30	200	17,5	16	5000
VDMP 6000	2 x 400	75	100-1200	3 x 450	36	170	17,5	16	6000
VDMP 8000	2 x 450	90	90-1100	3 x 450	36	170	24	12	8000
VDMP 10000	2 x 450	90	90-1100	3 x 500	58	160	24	12	10000
VDMP 12000	2 x 550	110	70- 850	3 x 500	58	160	24	12	12000
VDMP 15000	2 x 600	132	70- 800	3 x 600	68	140	24	10	15000

* Also available as **Vacuum-Mixing-Disperser**: Type VDMP-VA



Universal-Mixing-Disperser

The "VOLLRATH-Mixing-Disperser" is a universal device ideal for the processing of higher viscosity products with scraper, disperser and mixer.

Using all three elements; the slow speed rotor to incorporate the ingredients into the batch; the high speed disperser to break down and disperse powders into the liquid; the anchor with wall and bottom scrapers to clear the vessel surfaces of product and feed the product into the working areas of the mixer and disperser.

This ensures a quick and homogeneous processing.

Using just the mixer and anchor, and if required with the disperser running slowly more delicate additions to the process can be added without damaging them.

Higher viscosity products up to approximately **900,000 mPas** including adhesives, fillers, sealing compounds, foundry coatings, decorative plasters, masonry paints, primers and dispersion paints, can be easily processed with the "VOLLRATH-Mixing-Disperser".

Dispersers
Bead-Mills
Mixers
Stirrers

