

A vertical bar on the left side of the page with a color gradient from red at the top to blue at the bottom.

vollrath

Dispersers
Bead-Mills
Mixers
Stirrers

Mixers Stirrers

Applications

VOLLRATH-Mixers and -Stirrers are mainly used to efficiently mix and homogenise either solids into liquids or liquid into liquid.



Lenart-Disc

When fitted with the "Lenart-disc" they are well proven as an all-purpose tool in the paint and coatings industry. This type of disc creates an excellent vortex over a large range of viscosities having a relatively high peripheral tip speed (up to 13 m/s). Most different mixing tools are supplied from VOLLRATH for various applications: one-stage or multistage Stirrers as well as butterfly-, grid- and anchor-agitators.

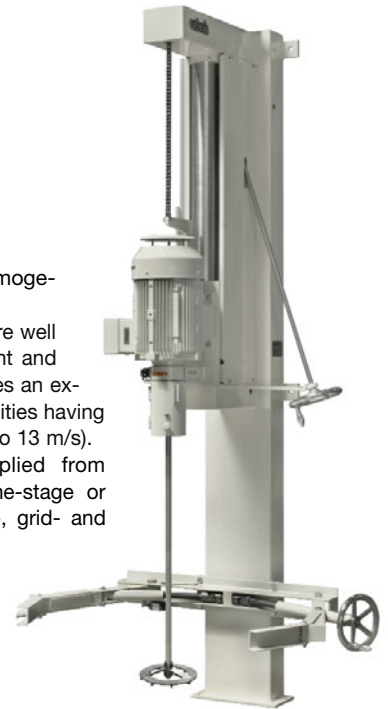

Efficiency, Flexibility and High Performance

The correct selection of mixing tools for a particular application ensures the most effective processing. We will gladly help you with the selection.

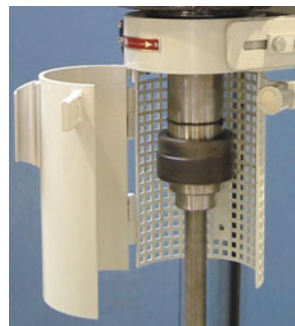

Quick coupling

Optimisation

The following options can be supplied to optimise the processing:

- Quick release couplings. This allows shafts fitted with different mixing tools (diameter, type, length) to be changed quickly to suit any particular application.
- All mixers can be with variable speed by using frequency inverters. This gives greater flexibility of mixing volumes/tool selection etc. along with easy and safe control over the whole speed range.
- Height adjustment of mixing tool. This along with variable speed allows the optimum mixing effect.
- Wall and bottom scraping systems can be added - when the Mixers are used with a wall and bottom scraper, highly viscous products can be easily processed.
- Vessels can be fitted with heating or cooling jackets.
- Mixers with conical vessels are normally supplied when a large variation in batch sizes or the whole process has to take place in one vessel.
- VOLLRATH can also supply mixers of special execution that can be developed with the customer. Universal-Mixing-Dispersers with up to three mixing systems, like the Type VDMP, can be supplied for a wide range of products.



Universal-Mixing-Disc

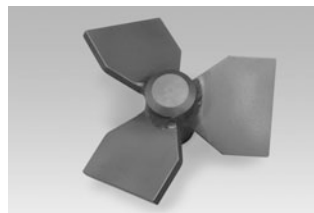

Propeller



Butterfly

Laboratory and Trials.

The VOLLRATH-Laboratory and demonstration room is available for trials to ensure correct selection of equipment to suit customer's particular requirements.

An adaptation of formulation can be necessary to reach optimal results.

Explosion-proof protection (ATEX)

Mixers can be supplied according to EC Directive 94/9/EG (ATEX) for use in all zones including zone 0. Notified body (PTB) certificates are available where required.

Vacuum-Mixers

The option "vacuum" is available for the most VOLLRATH-Mixers.

Construction and Service

All VOLLRATH-Mixers are solidly built and designed to give a trouble free long service life.





EWTKV 0,5 + EWTMV 0,5



EWTMH 0,5*

Laboratory-Mixers

Type	Discs Ø mm	Power kW	Speed min ⁻¹	Lift mm	Container Ø mm	Volume l
EWTKV 0,5	35/50/65/90	0,3	260-1820	200	80-300	0,4-4,9
EWTMV 0,5	35/50/65/90	0,3	260-1820	360	80-400	0,4-4,9
EWTMH 0,5*	35/50/65	0,3	0-6000	300	50-400	0,1-4,9

* Explosion proof is not possible.



EWT 2

Laboratory- and Pilot-Plant-Mixers

Type	Disc Ø mm	Power kW	Speed min ⁻¹	Lift mm	Container Ø mm	Volume l
EWT 2	100	1,1	145-2300	400	200-400	5-50

Dispersers
Bead-Mills
Mixers
Stirrers



To comply with local environmental and safety regulations our wall and stand mounted mixers are often supplied with lids.

The lid is fixed to the machine head on slides. This allows up and down movement of the mixers disc over its working area, to obtain the optimal mixing effect (Vortex), whilst the lid remaining in contact with the vessel/drum. Lids are fitted with large charging chutes allowing ingredients to be added (with the mixer operating) straight into the vortex. Fast incorporation of the ingredients is therefore ensured.

Sample:

Mixer Type EWG 10
with EC-Type Examination Certificate for "zone 0".

Mixer fitted with the electro-mechanical lifting option can easily be raised and lowered for vessel/drum removal, along with fine adjustment of the working height to suit mixing requirements.

These mixers offer excellent price/performance ratios.

Explosion Protection

Explosion proof Mixers with lid (closed system) are normally "zone 0" (category 1) rated inside the vessel.

Marking of machines for "zone 0" / zone 1

category 1 / category 2

vollrath		D 50354 Hürth Max-Planck-Str. 13	
Typ:	EWG 10		
Baujahr	2007	Masch. Nr.:	25.282
CE 0102	Ex II 1/2 G c IIB T3		
Richtlinie 94/9/EG	03ATEX5007X 08ATEX D011		
nk - 680 - 730 l/min	P = 7,5 kW, Scheibe max. d = 300		



Serial production according to Directive 94/9/EG (ATEX)
for zone 0, 1, 2, 20, 21, 22

Vollrath has two certified modular designs for "zone 0":

- for vessels working with atmospheric pressure.
- for vessels working under vacuum.

All Production-Mixers have "zone 0" explosion proof option available!



Wall- or Stand-Mixers

Type	Disc Ø mm	Power kW	Speed min ⁻¹	Lift mm	Container Ø mm	Volume l
EWGM 2	150	1,5	95-1660	500	400- 600	50- 150
EWGM 3	175	2,2	95-1425	500	600- 800	150- 400
EWGM 4	200	3,0	95-1250	500	650- 850	200- 450
EWGM 5	225	4,0	95-1100	500	750- 950	300- 650

Increased lift range and/or different speed range on request.

The stand version has a solid foot made of steel to screw the Mixer on the floor of hall.



Wall- or Stand-Mixers

Type	Disc Ø mm	Power kW	Speed min ⁻¹	Lift mm	Container Ø mm	Volume l
EWG 4	200	3,0	95-1250	600	650- 850	200- 450
EWG 5	225	4,0	95-1100	600	750- 950	300- 650
EWG 7	250	5,5	95-1000	600	850-1050	500- 900
EWG 8	275	5,5	72- 920	600	1050-1250	1000-1500
EWG 10	300	7,5	72- 830	600	1150-1350	1300-2000
EWG 15	350	11,0	72- 750	600	1250-1450	1700-2500
EWG 20	400	15,0	45- 625	600	1350-1600	2000-3000

Increased lift range and/or different speed range on request.

The stand version has a solid foot made of steel to screw the Mixer on the floor of hall.



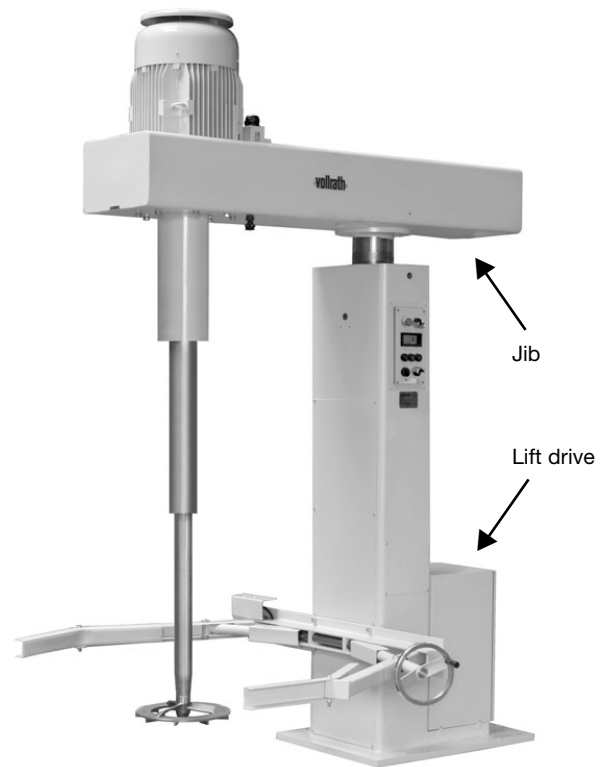

Wall- or Stand-Mixers

Type	Disc Ø mm	Power kW	Speed min ⁻¹	Lift mm	Container Ø mm	Volume l
EWSW 15	350	11,0	72-720	1200	1250-1450	1700-2300
EWSW 20	375	15,0	72-720	1200	1350-1550	1800-2300
EWSW 25	400	18,5	72-720	1200	1450-1550	2000-2300
EWSW 30	425	22,0	72-720	1200	1450-1550	2000-2300

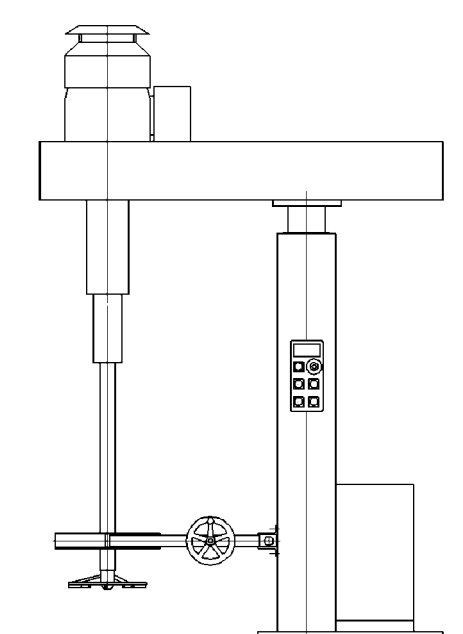

Stand-Mixer

The Stand-Mixer is to fasten on a floor by screws.

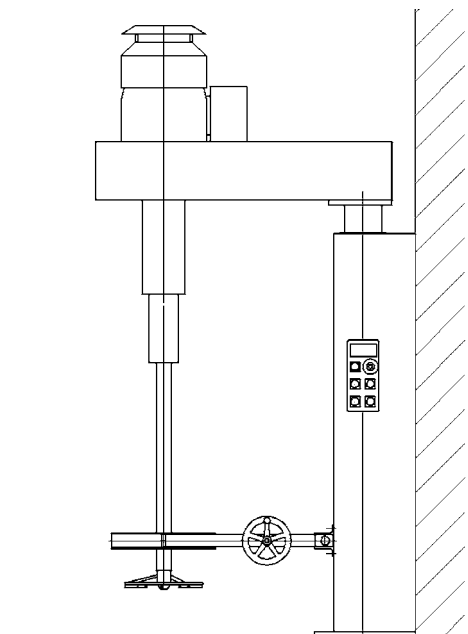

Wall-Mixer

The jib is shortened at the back and the lift drive is turned to left side.

The machine frame is to fix at wall or column by it's mounting brackets.



Top-Mounted-Stirrers with Lenart-Disc

Type	Disc Ø mm	Power kW	Speed min ⁻¹	Container Ø ¹ mm	Volume l
EDC 1 FU	100	0,75	145-2500	350	40
EDC 2 FU	150	1,5	145-1650	450	65
EDC 3 FU	175	2,2	95-1250	600	200
EDC 4 FU	200	3,0	95-1100	700	300
EDC 5 FU	225	4,0	95-1100	800	400
EDC 7 FU	250	5,5	72-1000	900	600
EDC 10 FU	300	7,5	72- 830	1050	1000
EDC 15 FU	350	11	72- 720	1200	1500



Top-Mounted-Stirrers with Lenart-Disc

Type	Disc Ø mm	Power kW	Speed min ⁻¹	Container Ø ¹ mm	Volume l
EU 10 FU	400	7,5	55-650	1400	2200
EU 15 FU	450	11,0	45-560	1600	3500
EU 20 FU	500	15,0	42-500	1750	4500
EU 25 FU	550	18,5	40-460	1950	6000
EU 30 FU	600	22,0	35-420	2100	7500
EU 40 FU	650	30,0	32-390	2300	10000
EU 50 FU	700	37,0	30-360	2500	12000
EU 60 FU	750	45,0	28-340	2600	15000

Dispersers
Bead-Mills
Mixers
Stirrers



Mobile Mixers

Type	Discs Ø mm	Power kW	Speed min ⁻¹	Lift mm	Container Ø mm	Volume l
EWF 3	175	2,2	95-1450	-	600- 800	150-400
EWF 4	200	3,0	95-1250	-	650- 850	200-450
EWF 5	225	4,0	95-1100	-	750-1000	300-800

Optional with lift up to 400 mm.



Rail-Mixers

Type	Disc Ø mm	Power kW	Speed min ⁻¹	Container Ø mm	Volume l
EWL 2 FU	150	1,5	145-1700	500- 700	100- 250
EWL 3 FU	175	2,2	95-1450	600- 800	150- 400
EWL 4 FU	200	3,0	95-1250	650- 850	200- 450
EWL 5 FU	225	4,0	95-1100	750- 950	300- 650
EWL 7 FU	250	5,5	95-1000	850-1050	500- 900
EWL 8 FU	275	5,5	72- 920	1050-1250	1000-1500
EWL 10 FU	300	7,5	72- 830	1150-1350	1300-2000
EWL 15 FU	350	11,0	72- 725	1250-1450	1700-2500

All Rail Mixers **optional with lift** for mixing tool to optimize mixing effect.

Rail-Mixers for **2 rails up to 30 kW Power** on request.



Stirrers with mounting-bracket for Shipping-Container

Type	Propeller Ø mm	Power kW	Speed min ⁻¹	Container Ø mm	Volume l
VRG 3	340/250	2,0	296	1000	1000
VRG 7	390/300	5,0	318	1000	1500

Optional with safety circuit for intermittent operation.



Top-Mounted-Stirrers with Universal-Mixing-Disc

Type	Disc Ø mm	Power kW	Speed min ⁻¹	Container Ø mm	Volume l
VRGM 10	375	7,5	40-390	1250	1500
VRGM 15	450	11,0	32-325	1400	2000
VRGM 20	550	15,0	28-270	1800	5000
VRGM 25	575	18,5	25-260	1900	6000
VRGM 30	650	22,0	22-225	2200	9000
VRGM 40	725	30,0	20-200	2350	11000
VRGM 50	825	37,0	18-180	2600	15000

Dispersers
Bead-Mills
Mixers
Stirrers

Top-Mounted-Stirrers

Type	Disc Ø mm	Power kW	Speed min ⁻¹	Container Ø ¹ mm	Volume l
VRGD 4	500	3,0	115	1250	1800
VRGD 8	700	5,5	80	1750	5000
VRGD 10	800	7,5	70	2000	7500
VRGD 15	900	11,0	65	2300	10000
VRGD 20	1100	15,0	50	2800	20000
VRGD 25	1200	18,5	45	3000	25000



Top-Mounted-Stirrers

Type	Discs Ø mm	Power kW	Speed min ⁻¹	Container Ø ¹ mm	Volume l
VRG 7	500/ 375	7,5	55-650	1100	1000
VRG 15	600/ 450	11,0	45-560	1350	2000
VRG 25	800/ 600	18,5	42-500	1700	4000
VRG 30	1000/ 750	22,0	40-460	2200	8000
VRG 40	1250/ 950	30,0	35-420	2600	16000
VRG 60	1500/1100	45,0	32-390	3000	25000



Anchor-Agitators

Type	Power kW	Speed min ⁻¹	Volume l
VRA 500	3,6	21	500
VRA 1000	5,5	21	1000
VRA 2000	10	21	2000
VRA 4000	17,5	16	4000
VRA 6000	17,5	16	6000
VRA 8000	24	12	8000
VRA 10000	24	12	10000
VRA 15000	24	10	15000

Optional in vacuum execution.

Different driving power and speed ranges on request.



Bottom- and Wall-Scrapers

Most of Anchor-Agitators are delivered with Bottom- and Wall-Scraper-Segments. They are hinged fastened and pressed against wall by spring load.

- The scraper-segments are alternately fastened to the anchor agitator with two arms, so they equalise tolerances of vessel optimally.
- The scraper-segments guarantee an outstanding heat transfer in combination with cooling of vessel.

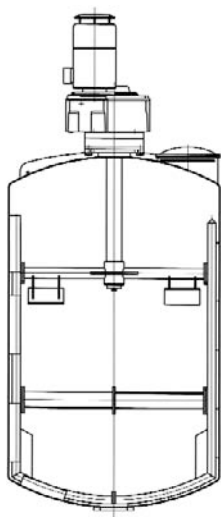
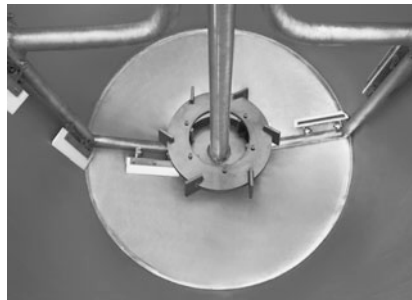

Anchor-Agitator with mixing effect for homogenizing, with scraper-segments.

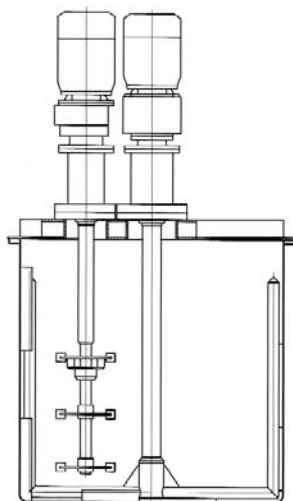

Combination of two Agitators: Anchor with scraper-segments and eccentric mixer.

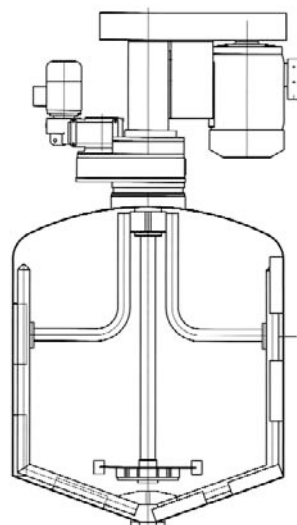

Combination of two Agitators: Anchor with scraper-segments and central mixer.

Vessel and Anchor are made by VOLLRATH:
Exact calibration by manufacturing in the own house.

Dispersers
Bead-Mills
Mixers
Stirrers

